

# The C-Class.

Coupé.



Mercedes-Benz



entral star, the strong shoulders, short overhangs and a powerfully thrusting tail end. Every design of the times. That's why the C-Class Coupé features optimised engine technology, the standard-fit ECO start/stop function and the optionally available 7G-TRONIC PLUS. Think. Thanks to numerous safety systems which take account of practically every event. It has the ability to apply the brakes in anticipation of danger. So, if the worst comes to this cockpit you will experience what cornering really means: the C-Class Coupé Sport lateral dynamics. The shortest route between two points now feels like a bend. Sport says more directly. The shift points change. The driving experience is intensified. You will turns into a bend sooner or later. If you're driving the C-Class Coupé, you'll probably p leather in black with contrasting red topstitching provide exceptional support and are tched off at all. **More style per hour.** Further interior highlights include the silver-coloured the foot is all it takes to get the blood really pumping. Further interior highlights inclu



The C-Class Coupé is an exciting blend of style and drive. Externally, it is a compellingly attractive, dynamic coupé which expresses a strong sense of forward motion. Inside, it is a place to sit back and relish every corner and twist in the road in an ambience of sportiness and functional perfection. The result is sheer driving enjoyment.

Support is provided by engines equipped with the ECO start/stop function as standard, the sporty set-up of the AGILITY CONTROL suspension with selective damping system, an electronic brake control system and features which set the standard for safety.

At a glance | from page 4    Insight | from page 22

Featured models:
<b>C 350   palladium silver metallic</b>   cover and from page 2 AMG 7-spoke light-alloy wheels, bengal red leather, dark longitudinal-grain aluminium trim, AMG sports package
<b>C 250 CDI   diamond white metallic BRIGHT</b>   from page 12 5-spoke light-alloy wheels in “sterling silver”, black ARTICO man-made leather, Style package
<b>C 250 Sport   designo magno platinum</b>   from page 16 7-twin-spoke light-alloy wheels in high-gloss black with high-shine finish, ARTICO man-made leather /DINAMICA microfibre in black

The illustrations may show accessories and optional extras which are not part of standard specification.

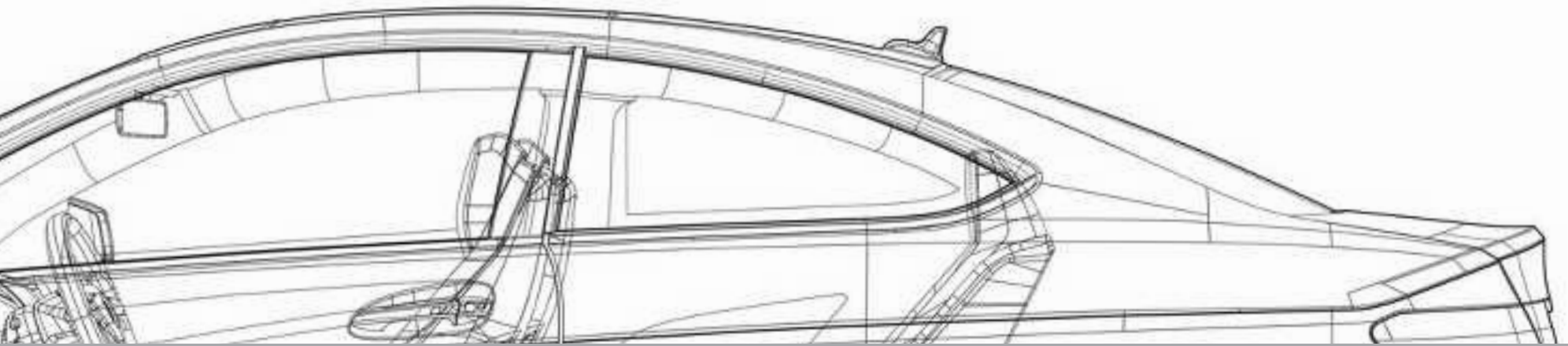

**Stylish agility:** Mercedes-Benz Intelligent Drive, BlueEFFICIENCY, diesel and petrol engines, transmissions and chassis.

Drive system & chassis | from page 28

**Reassuringly safe:** technologies in the integral safety concept for the “Safe driving”, “In the event of danger”, “In an accident” and “After an accident” phases.

Safety | from page 36

**Entertaining relaxation:** multimedia and assistance systems, interior appointments.

Comfort | from page 40

**Impressively laterally dynamic:** the C-Class Coupé Sport with superbly sporty cornering characteristics.

Model variant | from page 46

**Outstandingly driven:** the flagship C 63 AMG Coupé with a 6.3-litre V8 engine.

AMG | from page 48

**Desirable versatility:** standard equipment and optional extras, packages, light-alloy wheels and accessories.

Equipment & appointments | from page 54

**Exciting professionalism:** everything about Mercedes-Benz Financial Services, Mercedes-Benz mobility, Mercedes-Benz Museum, test drive, Interactive Owner’s Manual and Mercedes-Benz Guides, mobile internet, service contracts and accident repairs.

Services | from page 72

**Detailed listings:** technical data, dimensions and paintwork.

Facts & colours | from page 74



## Two doors, no compromises. As coupé as it gets!

The low silhouette with a long, arrow-shaped bonnet. The upright, louvred radiator grille with a central star, the strong shoulders, short overhangs and a powerfully thrusting tail end. Every centimetre underlines the character of this coupé: built for people who don't like to stand still.



Brief care instructions:  
needs tarmac beneath its tyres every day.







Are you concerned about the environment?  
We're right there with you.

Intelligent drive systems are a sign of the times. That's why the C-Class Coupé features optimised engine technology – with a choice of four efficient petrol variants and two diesel variants. Additional fuel-saving potential comes courtesy of the standard-fit ECO start/stop function and the optionally available 7G-TRONIC PLUS automatic transmission. Good news for CO<sub>2</sub> emissions. → Page 30–34



Welcome to the coupé lounge.







Maybe your first Mercedes.  
Almost certainly not your last.





A silver Mercedes-Benz C-Class Coupé is parked on an airfield. In the background, a private jet is visible on the tarmac. The car is positioned in the lower-left foreground, angled towards the right. The airfield is marked with orange and white traffic cones. The sky is clear and blue.

## Just what you need: a sixth sense.

The C-Class Coupé is always a bit further ahead than you think, thanks to numerous safety systems which take account of virtually every eventuality and help defuse hazardous situations. Take the ADAPTIVE BRAKE control system, which can apply the brakes in anticipation of danger. So if the worst comes to the worst, the car can be brought to a stop even more quickly. It's good for all concerned, not just your heart rate.

## Lateral dynamite.

In this cockpit you will experience what cornering really means: the C-Class Coupé Sport – engineered by AMG. The specially tuned AMG sports suspension and the more direct steering ensure tangibly greater lateral dynamics. The shortest route between two points now feels like a bend.









## S-plosion at the push of a button.

Sport says it all: with the touch of a button you sharpen the sports mode – S-Mode for short. The drive system then reacts tangibly more directly. The shift points change. The driving experience is intensified. You will ask yourself why the S-Mode can be switched off at all. The answer is: so that you can switch it back on again.

→ Page 46



## The sharpest centrifuge of all time.

Every road turns into a bend sooner or later. If you're driving the C-Class Coupé, you'll probably prefer it to be sooner. The AMG sports seats upholstered with ARTICO man-made leather/DINAMICA microfibre in black with contrasting red topstitching provide exceptional support and are equipped with red seat belts. Further interior highlights include the silver-coloured steering-wheel gearshift paddles, the brushed-aluminium trim with a dark longitudinal grain and the sports pedals in brushed stainless steel. A dab of the foot is all it takes to get the blood really pumping.





## Best-time machine.

The DTM AMG Mercedes C-Coupé has been built according to a meticulously designed safety concept with an innovative safety cell at its heart. This comprises a carbon-fibre monocoque plus a safety cage made of high-strength steel.

The C-Class family can already look back at a highly successful history. Even in its first season, 1988, Mercedes-Benz became the world championship runner-up in partnership with the AMG motorsport experts. The vehicle in question was the 190 E 2.5-16 EVO, the racing version of the famous C-Class predecessor. And Mercedes-Benz enjoyed success in the fight for the top positions in the years that followed, too: it was the runner-up in the world championships of 1991 and 1993, took its first DTM championship title in 1992 – and again in 1994, 1995, 2005, 2006 and 2010. The C-Class is the most successful vehicle in the history of the DTM.

But the C-Class has by no means seen its best time yet. For the goal is to achieve the best time in every race with the DTM AMG Mercedes C-Coupé, too.





28 **Mercedes-Benz Intelligent Drive**29 **BlueEFFICIENCY**30 **Diesel engines**

4-cylinder

32 **Petrol engines**

4-cylinder

6-cylinder

34 **Transmissions**

6-speed manual transmission

7G-TRONIC PLUS

35 **Chassis & suspension**

AGILITY CONTROL suspension

Dynamic Handling package with

Sport mode

36 **Integral safety concept**

ATTENTION ASSIST

Intelligent Light System

Adaptive Highbeam Assist

Lane Tracking package

Driving Assistance package Plus

PRE-SAFE® Brake and BAS PLUS

PRE-SAFE® system

NECK-PRO head restraints

Restraint systems

Active bonnet

Mercedes-Benz emergency call system

Measures after an accident

40 **Multimedia systems**

COMAND Online

Harman Kardon® Logic 7®

surround sound system

Audio 20

Becker® MAP PILOT

42 **Assistance systems**

Speed Limit Assist

Reversing camera

PARKTRONIC, including Parking Guidance

44 **Seats**

Coupé seats

Individual rear seats

Memory package

46 **C-Class Coupé Sport**

48 **C 63 AMG Coupé**50 **C 63 AMG technology**

AMG 6.3-litre V8 engine

AMG sports suspension

AMG SPEEDSHIFT MCT 7-speed

sports transmission

52 **AMG Performance Studio**54 **Standard equipment**55 **Optional extras**56 **Equipment packages**

AMG Sports package

AMG Plus Sports package

designo

Style package

62 **Upholstery and trim**68 **Wheels**

Standard wheels

Optional wheels

AMG wheels

70 **Genuine accessories**72 **Services**

Mercedes-Benz Financial Services

Mercedes-Benz mobility

Mercedes-Benz Museum

Test drive

Interactive Owner's Manual and

Mercedes-Benz Guides

Mobile internet

Service contracts

Accident repairs

74 **Dimensions**74|77 **Paintwork**75 **Technical data**

## Mercedes-Benz Intelligent Drive – a new era in mobility.

Our engineers focus on the future every day, the aim being to implement innovative technology. This aspiration has resulted in developments that have had a lasting impact on automotive engineering. In other words, we are working to make sure that a Mercedes-Benz will always be ahead of its time.

We have developed one groundbreaking solution after another to get closer to realising our vision of safe and accident-free driving. Innovative technologies such as the anticipatory occupant protection system PRE-SAFE® and DISTRONIC PLUS proximity control first made it onto the road in a Mercedes-Benz, setting new standards in vehicle safety. This is because it was the first time that active and passive systems had been combined – for even better protection and driving comfort.

Mercedes-Benz Intelligent Drive takes things a stage further by intelligently combining the sensors from various safety and assistance systems. For us, it's a logical progression as the traffic situation has changed. There are more vehicles on the road, the driver's job is becoming more complex and the likelihood of distraction is increasing.

To give the driver even more assistance and deal with the specific situation effectively, we have revolutionised the car once more: a Mercedes-Benz is now able to “see” better in all dimensions. It has an even better view of the road and other road users, and it can react to what it sees.

We have developed a stereo camera system that is capable of seeing in three dimensions. Together with further sensors, this produces a 360° all-round view – a precise image of the surroundings. If the driving assistance and safety systems detect danger, they can respond within a fraction of a second to provide the driver with the right support for the situation in hand: by braking in dangerous situations, for example, or by masking out the portion of the main beam affecting oncoming traffic.

Pioneer of innovation – Mercedes-Benz Intelligent Drive once again underlines our ambition to lead and points the way ahead to accident-free and autonomous driving. The following pages include further information about our safety and comfort systems. They are available as standard equipment or optional extras for the C-Class, depending on the model specification; further details can be found on pages 36–39 and 42–43.

## BlueEFFICIENCY – fast forward to tomorrow.

Mercedes-Benz brings the future of motoring to the road faster. With ever more efficient vehicles and a production process that wastes fewer and fewer resources. We call this all-encompassing approach BlueEFFICIENCY. By way of example, BlueTEC technology for the diesel engine reduces the nitrogen oxides in the exhaust gases by up to 90%, while the natural-gas drive NGT drastically reduces

emissions and fuel costs. Our hybrid models, featuring an intelligent combination of internal combustion engine and electric drive, can reduce fuel consumption significantly. What's more, electromobility is also moving into the fast lane with the SLS AMG Coupé Electric Drive. Meanwhile, technical and aerodynamic enhancements right down to the last detail make the BlueEFFICIENCY Editions

available in selected model series true champions of efficiency.

But every C-Class model already boasts a raft of BlueEFFICIENCY features – comprehensive vehicle optimisation measures that have been adapted specifically for this model series.



- 1 Radiator shutter.
- 2 Improved aerodynamics.
- 3 Weight optimisation.
- 4 Engine optimisation.
- 5 Intelligent energy management.
- 6 ECO start/stop function.
- 7 Driver information for energy-saving driving.
- 8 Tyres with optimised rolling resistance.
- 9 Energy-saving control of ancillary components (power steering pump, fuel pump in the case of diesel engines).
- 10 Refrigerant compressor only activated when actually needed.

## Diesel engines.

The diesel engines for the C-Class Coupé make for efficient, refined and powerful progress. They have higher outputs yet can consume far less fuel than their conventional counterparts.

**4-cylinder engines.** The diesel powerplants incorporate a wealth of efficient technology. As a result, their output is up to 20% higher than that of comparable older engines: the C 220 CDI delivers 125 kW (170 hp), the C 250 CDI 150 kW 204 (hp). At the same time, the torque of both engines has been increased by up to 25%, while fuel consumption

and CO<sub>2</sub> emissions are up to 23% lower. Both models meet the requirements of the Euro 5 emissions standard.

One of the reasons behind the impressive performance of the diesel engines is the maximum injection pressure of up to 2000 bar. What's more, the required fuel quantity is metered extremely precisely – a sound basis for efficient and on-demand use of energy.

The diesel engines' good consumption/output ratio is also down to their optimised combustion chamber design, which offers ideal conditions for maximising both clean combustion and energy efficiency. At the same time, the optimised alternator management contributes to lower consumption. A further technology which promotes responsible-minded driving pleasure is the efficiency-enhancing turbocharger. Plus there are two balancer shafts to ensure even smoother running.

**Further efficiency measures.** All models are equipped as standard with the ECO start/stop function which automatically turns off the engine when waiting at traffic lights or in a tailback. The ECO display available for many models provides feedback about the efficiency of the driving style which can then be adapted accordingly to reduce fuel consumption.

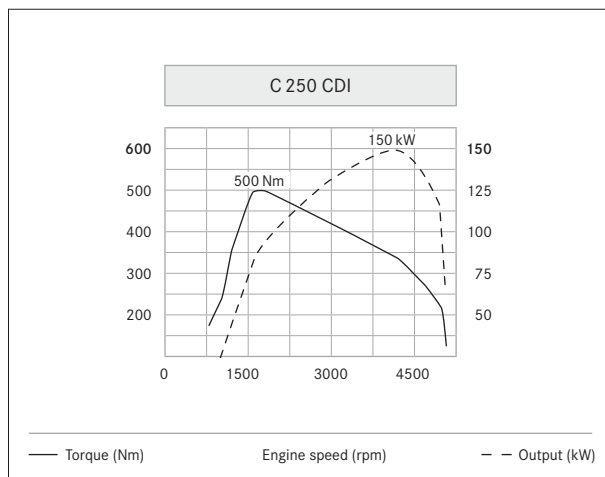

Impressive torque, even at low revs: ideal for spontaneous bursts of speed.



The ECO display provides feedback about the efficiency of your driving style.



The 4-cylinder diesel engine is available with a choice of two outputs (C 220 CDI shown here).



The 6-cylinder engine for the C 350 combines agility with responsible-minded energy consumption.

## Petrol engines.

Agility and efficiency go hand in hand, as demonstrated by the petrol engines. Both the 4-cylinder models and the V6 powerplant combine a high level of refinement with low fuel consumption.

**4-cylinder engines.** The current generation of 4-cylinder petrol engines pursues one major goal: more output and better acceleration figures in conjunction with lower fuel consumption. This is thanks to the direct injection system with an injection pressure of up to 200 bar, which ensures optimum preparation of the air/fuel mixture and therefore

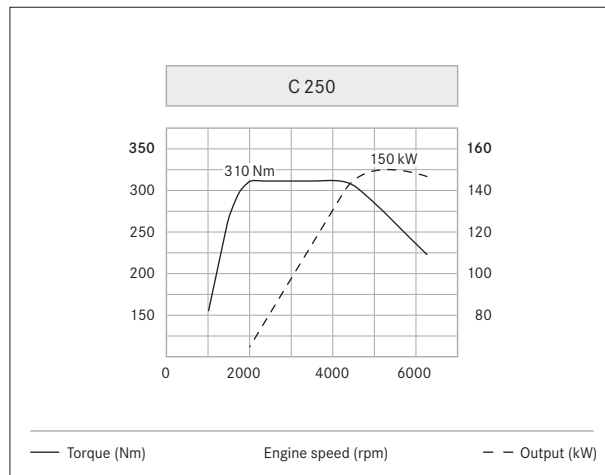

Not just remarkable in terms of performance data. The fuel-consumption figures are impressive, too.

increases the effectiveness of the engine. The engine management also optimises the valve timing through continuously variable camshaft adjustment and piezo-controlled injectors with multi-hole valves. Savings have been achieved when it comes to the engine weight, in particular: the cylinder crankcase, for example, is made of aluminium and the crankcase was cast hollow. Further optimisations reduce consumption over and above this. They include ancillaries controlled according to requirements or, for example, the electromechanical steering system in the C 180. This only requires energy during the actual process of steering – without any compromises in terms of steering comfort.

Performance potential: the C 180 accelerates from 0 to 100 km/h in just 8.5 seconds and goes on to reach a maximum speed of 225 km/h. The C 200 has a top speed of 237 km/h and completes the sprint from 0 to 100 km/h in just 8.2 seconds. The C 250 has a top speed of 240 km/h and completes the sprint from 0 to 100 km/h in 7.2 seconds.

**6-cylinder engine.** Economical, clean and high-torque: the C 350 heralds the arrival of a new generation of technology – drive concepts that are sparing in their use of resources. With combined fuel consumption of 7.0–6.8 l/100 km, the engine has a peak output of 225 kW (306 hp) and can accelerate the C-Class Coupé from 0 to 100 km/h in a mere 6.0 seconds. The maximum torque of 370 Nm is on tap across a particularly wide engine speed range, so impressive power reserves are available for practically any driving situation.

**Further efficiency measures.** All models are equipped as standard with the ECO start/stop function which automatically turns off the engine when waiting at traffic lights or in a tailback. The ECO display available for many models provides feedback about the efficiency of the driving style which can then be adapted accordingly to reduce fuel consumption.

## Transmissions.

The two transmissions available for the C-Class Coupé deliver optimum pulling power in every driving situation.

**6-speed manual transmission.** The 6-speed manual transmission combines sporty and economical driving. The ratio optimised in line with the engine output and the extremely precise, short shift travel make for exceptionally smooth gear changes. What's more, the integral gearshift-recommendation function, ECO start/stop function and current consumption indicator can help to optimise fuel consumption and reduce emissions. For instance, the ECO start/stop function stops the engine when the car is at or coming to a standstill – at traffic lights, for example – before restarting it when the clutch or accelerator pedal is pressed.

**7G-TRONIC PLUS.** The efficiency-optimised 7G-TRONIC PLUS automatic transmission is one of the major factors behind the exceptionally high level of driving enjoyment. The seven forward gears allow a constantly optimised rpm level, meaning that fuel consumption can be reduced. But the transmission technology also comes into play when the driver wants to accelerate powerfully or experience the full range of the C-Class Coupé's agility. For example, individual gears can be skipped when overtaking or in situations requiring spontaneous acceleration. Furthermore, the transmission modes "E" (Economy) and "S" (Sport) can be selected at the touch of a button.

In conjunction with the optional AMG Sports package or AMG Plus Sports package and the optional Dynamic Handling package with Sport driving mode there is an additional driving mode, "M", for manual shifting via the steering-wheel gearshift paddles. 7G-TRONIC PLUS is available as standard in the C 250 CDI Sport, in the C 250, in the C 250 Sport and in the C 350; for the other models this transmission is available as an option.



7G-TRONIC PLUS: one of over 18 million automatic transmissions produced in a period spanning more than 50 years.

## Chassis & suspension.

The chassis technology for the C-Class Coupé allows comfort-oriented or sporty driving with supreme agility in almost any situation on the road.

**AGILITY CONTROL suspension** (standard). The suspension with selective damping system can adjust automatically to the current road conditions and driving style. To do this, a valve automatically reduces the damping force at each wheel when the shocks caused by the road are weaker, thus lowering road roar and tyre vibration. If these shocks are stronger, the system's damping effect is enhanced and can improve the car's driving stability.

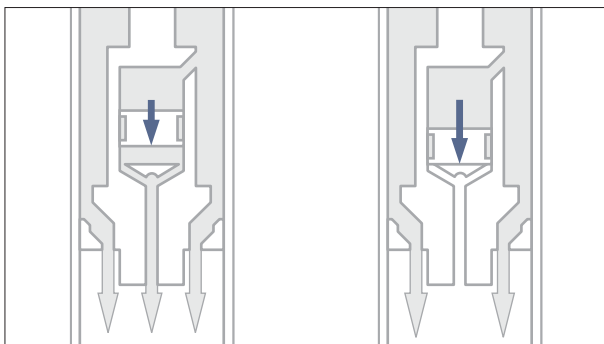

Outstanding agility and a high level of comfort: the AGILITY CONTROL suspension can adapt to any driving style.

**Dynamic Handling package with Sport mode** (option). This optional package enhances driving dynamics and driving enjoyment on every trip. There are three transmission modes – Economy, Manual and Sport – and the lateral dynamics can be controlled separately in Sport mode. S mode initially alters the settings of the 7G-TRONIC PLUS automatic transmission and tangibly changes the accelerator characteristics – so the engine is more responsive, which enhances longitudinal dynamics. Furthermore,



A suspension system lowered by 15 millimetres is one of the features which complements the Dynamic Handling package.

stiffer suspension settings can be selected, allowing even sportier driving with noticeably enhanced lateral dynamics. Driving enjoyment on fast corners is boosted significantly if the chassis is lowered by 15 mm. With its modified steering response map and a direct ratio, the speed sensitive sports steering delivers an exceptionally sporty and agile driving feel that is complemented perfectly by a 3-spoke multifunction steering wheel in nappa leather with gearshift paddles (in conjunction with automatic transmission).

Whatever the selected mode, the electronically controlled damping system adjusts to driving and road conditions.

## Integral safety concept.

The vision of accident-free driving impels us. With our integral safety concept we are coming closer to achieving this goal – this is a holistic approach which can increase safety in every situation.

As the inventor of the car we feel that we have a special responsibility for road safety. This is why we are the first car manufacturer to have developed an integral safety concept which seamlessly blends measures to enhance active and passive safety. The holistic approach is subdivided into four phases and offers safety solutions for every situation. It includes systems for safe driving which help to avoid risks by warning you and coming to your aid in good time. Our unique PRE-SAFE® system<sup>1</sup> is activated in the event of danger and initiates preventive measures for occupant protection. If a collision should still occur in spite of all the preventive measures, further technologies ensure protection as needed. We have also borne in mind the time immediately following an accident and developed solutions which can help prevent worse and facilitate rapid help.

A selection of these technologies for the “Safe driving”, “In the event of danger”, “In an accident” and “After an accident” phases is presented on the pages which follow.

**Safe driving: ATTENTION ASSIST<sup>1</sup>** (included with the optional luxury multifunction steering wheel, standard for C 350). ATTENTION ASSIST warns the driver and recommends taking a break as soon as it detects signs of driver drowsiness. To do this, it monitors the driver’s behaviour and, if this deviates from a previously determined profile, visual and acoustic warnings are emitted.

**Safe driving: Intelligent Light System<sup>1</sup>** (option). The system has five settings to improve your visibility and that of other road users: country mode illuminates the road verge whilst motorway mode illuminates the entire width of the road. The enhanced fog lamps improve visibility in poor weather, whereas the active light function and cornering light function follow the driver’s movements of the steering wheel.

**Safe driving: Adaptive Highbeam Assist<sup>1</sup>** (option). Adaptive Highbeam Assist maximises the range of the low-beam headlamps and can adjust it continuously in line with the prevailing traffic conditions. High beam is activated if no other road users are detected. The headlamps are dimmed automatically as soon as oncoming traffic is detected.

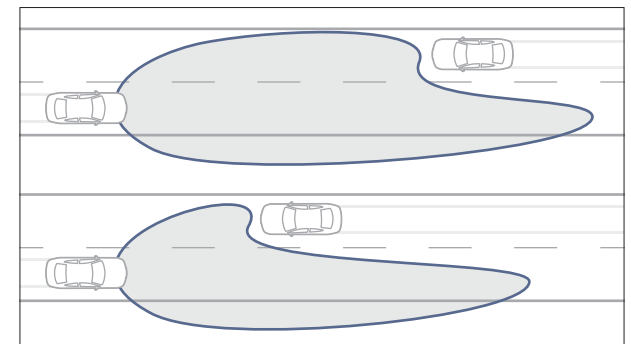

The Adaptive Highbeam Assist detects other road users with their lights on and ensures the best possible range of vision.

<sup>1</sup> Integral component of Mercedes-Benz Intelligent Drive. More on page 28.

**Safe driving: Lane Tracking package<sup>1</sup>** (option). Lane Keeping Assist<sup>1</sup> can detect a traffic lane based on the road markings and, if the car is about to leave its lane unintentionally, warn the driver by making the steering wheel vibrate gently. Blind Spot Assist<sup>1</sup>, meanwhile, uses two radar sensors in the rear bumper to monitor the blind spot at speeds above 30 km/h and can warn the driver against dangerous lane changes. Lane Keeping Assist and Blind Spot Assist are also available separately as individual options.



Blind Spot Assist can warn of potential dangers acoustically and by means of a red warning triangle in the exterior mirror.

**Safe driving: Driving Assistance package Plus<sup>1</sup>** (option). At the touch of a button, the DISTRONIC PLUS<sup>1</sup> adaptive cruise control can help the driver to maintain a set distance behind the vehicle ahead of it at speeds between 0 and 200 km/h and, if it detects the need, initiate braking. If necessary, the radar-based system can brake the car to a standstill. Active Blind Spot Assist<sup>1</sup> helps the driver when turning or changing lanes. A warning triangle lights up in the appropriate exterior mirror if a vehicle is detected in the blind spot. If the driver fails to respond, the system

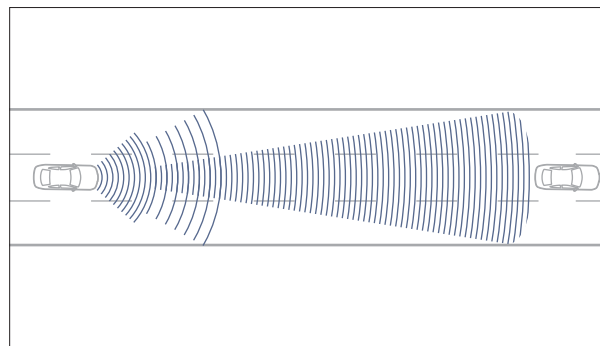

DISTRONIC PLUS can help drivers to automatically keep their vehicle at a safe distance from the vehicle in front.

can prevent a possible accident by automatically braking individual wheels. If the vehicle unintentionally crosses the detected lane markings and risks leaving its lane, Active Lane Keeping Assist<sup>1</sup> can warn the driver by gently vibrating the steering wheel. If there is still no response, individual wheels can be precisely braked to bring the vehicle back into lane. The system recognises contrasts on the road ahead and is therefore able to “read” lane markings. It also observes driving style and the line taken by the car, analysing these for movements typical of a vehicle leaving its lane unintentionally. In this way, the system is able to distinguish reliably between intentional and unintentional lane departures. The Driving Assistance package Plus is completed by the BAS PLUS<sup>1</sup> braking assistance system and the PRE-SAFE<sup>®</sup> Brake<sup>1</sup> – for a safe feeling on every journey.

**In the event of danger: PRE-SAFE® Brake<sup>1</sup> and BAS PLUS<sup>1</sup>** (components of the optional Driving Assistance package Plus<sup>1</sup>). PRE-SAFE® Brake gives the driver a visual warning, then an acoustic alert, if a risk of collision is detected. During this phase, BAS PLUS calculates the brake pressure necessary to prevent a collision. If the braking force applied by the driver is not sufficient, the system automatically increases brake pressure in a way that ensures the remaining braking distance is used to the fullest advantage. This means that the driver of the vehicle behind also has a better chance of avoiding a rear-end collision.

If the driver fails to respond to the signals, PRE-SAFE® Brake intervenes with autonomous partial braking, giving the driver a tangible warning. At the same time, the PRE-SAFE® system also triggers other protective measures in preparation for a possible collision. Autonomous emergency braking can then be activated if there is still no reaction from the driver. The result is a significant reduction in impact speed and accident severity.

<sup>1</sup> Integral component of Mercedes-Benz Intelligent Drive. More on page 28.

**In the event of danger: PRE-SAFE® System<sup>1</sup>** (option). This anticipatory occupant protection system is able to detect certain critical driving situations in advance and activate preventive measures. If an imminent accident is detected, the system closes the side windows, moves the front passenger seat equipped with the Memory package to a more favourable position and tensions the front seat belts automatically. It can also close the sliding sunroof where fitted.

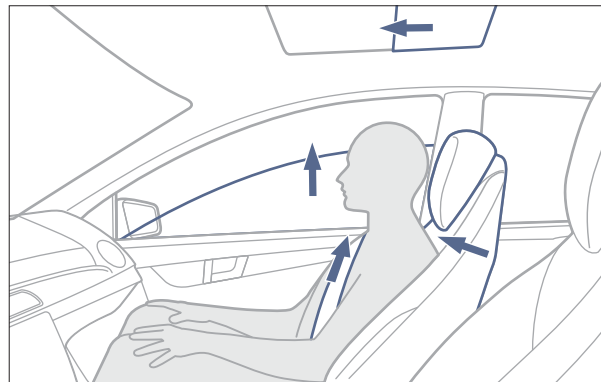

The PRE-SAFE® anticipatory occupant protection system helps to mitigate the consequences of accidents.

**In an accident: NECK-PRO head restraints** (standard). In the event of a rear impact, the sensor-controlled NECK-PRO head restraints for the front occupants are pushed forward and upward within a matter of milliseconds. They can thus reduce the gap between the head and the head restraint, thereby reducing the risk of injury.

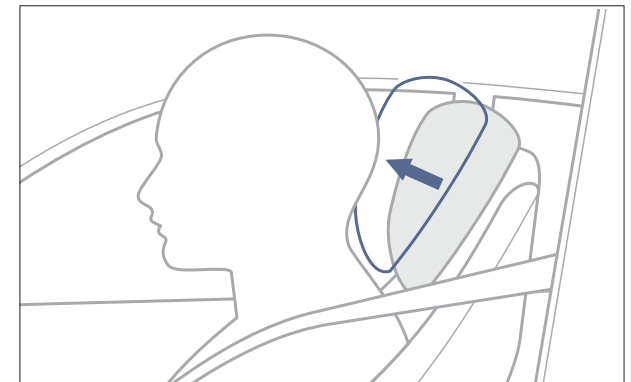

The NECK-PRO head restraints can help to reduce the risk of whiplash in an accident.

**In an accident: restraint systems** (standard). 3-point seat belts, belt tensioners, belt force limiters and airbags are optimally coordinated with each other at Mercedes-Benz, so as to keep injuries to a minimum wherever possible. The C-Class Coupé has numerous airbags which can help prevent injuries to the driver and passengers in case of a collision: the driver's and front-passenger airbags, sidebags and pelvisbags at the front are standard, as is a kneebag for the driver plus windowbags. Sidebags for the rear are

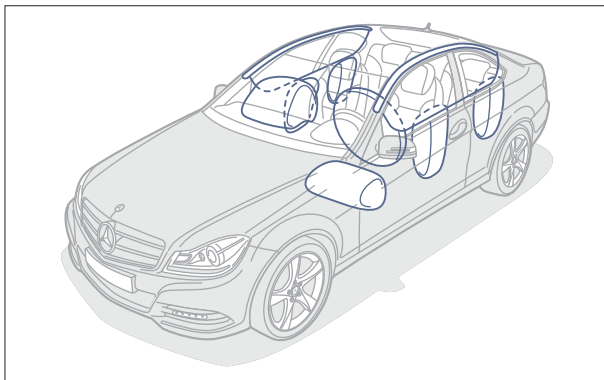

The robust passenger cell with defined crumple zones and the numerous airbags contribute to the exemplary occupant protection.

also available as an option. If the crash sensors detect an accident the seat belts are automatically tightened at lightning speed in order to keep the occupants firmly in their seats – this feature is also standard in the rear. The belt force limiter, meanwhile, relaxes the belt during the accident in accordance with the particular situation in question, so as not to place too much of a strain on any of the occupants' chest areas.

**In an accident: active bonnet** (standard). The active bonnet can reduce the risk of injury to pedestrians and cyclists. In the event of an impact, its rear section is raised around five centimetres by means of spring force, thus creating additional deformation space to soften the blow for a pedestrian or cyclist.

**After an accident: Mercedes-Benz emergency call system** (part of COMAND Online). This system can make an emergency call automatically using a mobile phone which is on standby and connected to the vehicle as soon as

the restraint system detects an accident. At the same time, the GPS position data and other data about the vehicle are transmitted to the Mercedes-Benz emergency call centre, after which a voice connection is established. The emergency control system can also be triggered manually.

**Measures after an accident.** In order to reduce consequential damage and, where necessary, to support the rescue of the occupants, Mercedes-Benz has developed further measures. These include the automatic engine cut-off or the activation of the hazard warning lamps and interior emergency illumination. The central locking also opens automatically, and crash joints between the door and the wing make it easier to open the doors after a front impact. In addition Mercedes-Benz makes Guidelines for Rescue Services available; helpers can download them in different languages all over the world from the internet at [www.mercedes-benz.de/rettungsleitfaden](http://www.mercedes-benz.de/rettungsleitfaden). As you can see, at Mercedes-Benz consideration has been given to safety in every situation.

## Multimedia systems.

To drive in style, you also need quality entertainment and helpful navigation. Cue our outstanding entertainment electronics and excellent navigation systems.



As well as displaying navigation data in high resolution, the large TFT display also optimises the display of web and multimedia content.

**COMAND Online** (option). The multimedia system boasts a high-resolution 17.8-cm colour display. The system's functions include a radio, speed-sensitive volume control, the Music Register with a 10 GB hard disc and hard-disc navigation. What's more, it also includes free European map data updates for three years following initial registration. The best in entertainment is provided courtesy of the DVD player, which can play CDs and MP3 files as well as video and audio DVDs. The online function facilitates access to the internet and various Mercedes-Benz mobile services via a web-enabled mobile phone. By way of example, LIVE TRAFFIC receives the latest, accurate traffic information and feeds this directly into the navigation system. A USB connection, an Aux-in socket, a slot for SD memory cards and a Bluetooth® interface allow connection to external data storage media and a mobile phone. The system is operated using the central Controller and the buttons on the 3-spoke multifunction steering wheel. The LINGUATRONIC system allows you to control COMAND Online using voice commands.

**Harman Kardon® Logic 7® surround sound system** (option). The surround sound system with 450 watts is sure to make every one of your journeys an acoustic experience to savour. Twelve high-performance speakers and the Logic 7® multi-channel surround sound technology provide a three-dimensional sound impression. The automatic volume control adapts the sound in line with the car's current speed.



All you need for pure musical enjoyment: the Harman Kardon® Logic 7® surround sound system.

**Audio 20 with Bluetooth® interface and USB connection** (standard). Includes a radio function as well as a CD player with MP3 capability. The system is controlled via the multi-function steering wheel and the TFT display with a screen diagonal of 14.7 cm. A mobile phone can be linked via Bluetooth® for hands-free operation. There are also numerous interfaces available.



Audio 20 with eight precisely tuned speakers for delivering outstanding sound.

**Becker® MAP PILOT** (option). The Becker® MAP PILOT reliably gets you to your destination and has everything you look for in a sophisticated navigation system. It is installed in the glove compartment and can be simply controlled via the central Controller and the Audio 20 CD system's display. What's more, it can be further personalised by downloading updated map data and additional functions.

## Assistance systems.

The C-Class Coupé is designed to help you relax on the way to your destination. That's why it offers systems that can assist you and make your life easier in a wide range of traffic situations, for example when parking, when driving from city to city on roads with variable speed limits or when facing challenging road conditions.



Speed Limit Assist shows the driver the current speed limit.

**Speed Limit Assist** (included with the optional COMAND Online system). Speed Limit Assist can detect speed-limit signs and display them as symbols on the instrument cluster and in COMAND Online on the navigation screen. They remain displayed there until the speed restriction is lifted or changed. To this end, a windscreen-mounted camera monitors the area in front of the car on a permanent basis. The camera can filter out round traffic signs, be they speed-limit signs at the side of the road or on a gantry above the road. To detect the signs, the system also draws on the data stored in the navigation system's digital map, thus also enabling it to take account of the vehicle entering or leaving urban areas. Speed Limit Assist is especially helpful on routes with variable speed limits or road works.

**Reversing camera**<sup>1</sup> (option). The reversing camera with a wide-angle lens monitors the area directly behind the car and sends the images to the COMAND display. It is activated when reverse gear is engaged, thus enhancing safety when reversing into a parking space. The reversing camera is only available in conjunction with COMAND Online.



The reversing camera makes it easier to perform many manoeuvres when space is at a premium.

**PARKTRONIC**<sup>1</sup> incl. **Parking Guidance** (option). PARKTRONIC can warn the driver automatically if space in front of or behind the car becomes tight when parking or manoeuvring. The system operates on the echo sounder principle. Sensors on the front and rear bumpers emit ultrasound signals which are then reflected by other vehicles or obstacles. A microcomputer calculates the current distance and informs the driver by means of displays in the instrument cluster and via acoustic signals. Parking damage can therefore be prevented. Parking Guidance can help the



Parking Guidance automatically calculates the length of parking spaces at speeds up to 35 km/h.

driver when looking for a parking space and also when parking: ultrasonic sensors in the side front bumper can measure the length of parking spaces parallel to the car automatically if the car drives past at a speed of 35 km/h or less. Parking Guidance starts once a suitable space has been found and reverse gear has been engaged. It provides the driver with visual and acoustic instructions regarding the correct steering angle as well as the turn-in and turn-back points on the instrument cluster. If the car is not straight after the first reversing move, the system also helps the driver with the required manoeuvres.

<sup>1</sup> Integral component of Mercedes-Benz Intelligent Drive. More on page 28.

## Seats.

The C-Class Coupé is fitted with specially designed coupé seats including integral head restraints and luxury single rear seats. As well as being style-defining, the seat design offers extremely effective support, even during sporty driving, and perfect ergonomics.



The standard-fit coupé seats are ergonomically designed. You can tell that they are made for a highly agile car: the C-Class Coupé.

**Coupé seats.** Ergonomic coupé seats upholstered in a combination of ARTICO man-made leather and fabric await the driver and front passenger; ARTICO man-made leather or genuine leather upholstery is optionally available. Both the seat cushion height and the backrest inclination are electrically adjustable at the push of a button. Heated or climatized seats are available as optional extras.

**Individual rear seats with integral head restraints.**

The lounge-like character of the interior is also reflected in the ergonomic, individual design of the rear seats with integral head restraints. An asymmetrically split and folding rear seat backrest is included as standard (except in the C 180). Convenience is further enhanced by the manually operated EASY-ENTRY system, which makes it easier to get into and out of the car.



Sheer comfort: it's easy for rear passengers to get into the car thanks to the EASY-ENTRY system, which moves the front seats fully forwards in one simple move.

**Memory package** (option). This package extends the range of seat settings and, if several people drive the car, ensures that each driver can adopt their preferred sitting position quickly by calling up their own pre-programmed settings – for the driver's seat, steering column and exterior mirrors – at the touch of a button. In addition to this, the Memory package includes a 4-way lumbar support for both the front seats.



The ergonomic driver's seat moves into the pre-programmed desired position at the touch of a button.



The Sport models feature black-painted exterior mirrors and a radiator grille with twin louvres in high-gloss black.



The sports exhaust system with active sound shaping for a racing-car sound.

## C-Class Coupé Sport.

The C-Class Coupé Sport – engineered by AMG – turns every bend into a special experience. For the sharpest cornering and lateral dynamics in its class the vehicle boasts an exclusively tuned AMG sports suspension. Acoustically, the rich sound of the sports exhaust system provides the backdrop for the powerful propulsion. The specially configured sports mode makes the engine react tangibly more directly, as it changes the shift points and shortens the response times with a double-declutching function. And when braking with the sports braking system the transmission actively shifts down. As well as ensuring sporty and dynamic performance on every journey, the technology also looks the part: the AMG spoiler lip, AMG bodystyling and AMG light-alloy wheels simply exude sportiness.

The C-Class Coupé Sport includes the AMG Plus Sports package and is rounded off by the following technical and design components:



AMG 7-twin-spoke light-alloy wheels, painted in high-gloss black with a high-sheen finish.

---

#### C-Class Coupé Sport

---

AMG 7-twin-spoke light-alloy wheels, painted in high-gloss black with a high-sheen finish

AMG lowered sports suspension with set-up optimised for lateral dynamics

Exterior mirrors painted black

Radiator grille featuring twin louvres in high-gloss black with chrome trim

Speed-sensitive sports steering with more direct ratio

Sports braking system with larger brake discs, including perforated front brake discs, callipers with "Mercedes-Benz" lettering

Sports exhaust system – including active sound shaping for the C 250 CDI Sport model

Sports-tuned engine and transmission in S/M mode

- More agile accelerator pedal characteristics with more direct response

- Shorter shift times

- Gear changes with double-declutching function

- Active downshifting when braking

"Sport" label on the side wings

---



The AMG sports seats in ARTICO man-made leather/DINAMICA microfibre upholstery provide optimum support.



## C 63 AMG Coupé.

The C 63 AMG is the epitome of an expressive coupé. The AMG front apron, the AMG radiator grille with one chrome louvre, the unique AMG bonnet with powerdomes, the unique AMG daytime running lamps, the side sill panels and the rear apron with inset diffuser are just some of the features that demonstrate its commitment to performance. The AMG sports exhaust with two chromed twin tailpipes likewise emphasises the high-performance credentials of the coupé and shows unequivocally that this particular Mercedes-Benz is powered by an AMG drive system. The exterior is completed to perfection by AMG light-alloy wheels, further underlining the fact that this is a highly responsive car built for motoring enjoyment. Further exterior features are listed below.

---

### Exterior

AMG 5-twin-spoke light-alloy wheels, painted titanium grey with a high-sheen finish, with 235/40 R 18 front tyres and 255/35 R 18 rear tyres

AMG bodystyling, comprising front apron with side air outlets and cross strut in high-gloss black, side sill panels and diffuser-look rear apron

AMG high-performance braking system with 360 x 36 mm front brake discs and 330 x 26 mm rear brake discs

AMG spoiler lip on the boot lid

Distinctive, flared front wings with "6.3 AMG" lettering

Tail lights with LED technology

---



Powerful on the outside, stylish on the inside. The interior concept of the C 63 AMG Coupé is well thought-out, right down to the last detail. As soon as you open the doors, the AMG door sill panels tell you that this car is something truly special. Passengers are then welcomed by AMG sports seats upholstered in a combination of ARTICO man-made leather and DINAMICA microfibre in black or, as an option, designo leather (single-tone or two-tone). The AMG performance steering wheel, featuring flattened top and bottom sections, has aluminium shift paddles, while the AMG instrument cluster with a colour display and AMG Start-up indicator is in an ergonomically ideal position. The black headlining and the AMG sports pedals complete the sporty ambience. → [www.mercedes-amg.com](http://www.mercedes-amg.com)



---

#### Interior

---

AMG door sill panels in brushed stainless steel

---

AMG instrument cluster with 11.4 cm high-resolution colour display, incl. RACETIMER and AMG Start-up indicator

---

AMG performance sports steering wheel in nappa leather, with flattened top and bottom sections as well as silver-coloured aluminium gearshift paddles

---

AMG speed-sensitive sports steering

---

AMG sports seats in ARTICO man-made leather/DINAMICA microfibre in black

---

ATTENTION ASSIST<sup>1</sup>

---

Brushed stainless-steel sports pedals with rubber studs

---

High-gloss black piano-lacquer-look trim

---

Rotary switch for selecting the four transmission modes and Race Start function

---

<sup>1</sup> Integral component of Mercedes-Benz Intelligent Drive. More on page 28.

## C 63 AMG technology.

The AMG 6.3-litre V8 engine and the AMG SPEEDSHIFT MCT 7-speed sports transmission offer an emotional driving feel and driving dynamics at the highest level. But when it comes to choosing a sporty or comfort-oriented driving style, the driver always has the final say in the C-Class Coupé. → [www.mercedes-amg.com](http://www.mercedes-amg.com)

**AMG 6.3-litre V8 engine.** A high-revving naturally aspirated engine with thoroughbred motor-racing technology: the vertical arrangement of the intake and exhaust ducts as well as the magnesium variable-intake manifold with two integral throttle valves ensure optimum charging of the eight cylinders. Further high-tech features include the variable camshaft adjustment, the four-valve-per-cylinder design, the stiff aluminium crankcase and the low-friction TWAS (twin-wire-arc-spraying) coating used for the cylinder walls. The V8 powerplant develops 336 kW (457 hp) at 6800 rpm, delivering impressive pulling power and a maximum torque of 600 Nm at 5000 rpm. Ideal ingredients for powerful acceleration in every engine speed range, as the driver always has over 500 Nm on tap between 2000 and 6250 rpm. Adding the AMG Performance package boosts the output by 22 kW (30 hp) to 358 kW (487 hp), enabling the car to accelerate from 0 to 100 km/h in a highly impressive 4.3 seconds.

**AMG sports suspension.** Superlative driving dynamics and thrilling driving enjoyment come courtesy of the AMG sports suspension with AMG 5-twin-spoke light-alloy wheels with 235/40 R 18 front tyres and 255/35 R 18 rear tyres in combination with the specially designed three-link front suspension with a wider track, the AMG speed-sensitive sports steering and the three-stage ESP<sup>®1</sup>. The AMG speed-sensitive sports steering has an even more direct ratio and, therefore, offers greater steering precision at high cornering speeds. The AMG sports suspension's stiff springs, gas-pressure shock absorbers and unique axle kinematics provide optimum agility at the driving limits as well as outstanding lateral dynamics. The AMG sports suspension therefore combines driving dynamics at the highest level with hallmark Mercedes long-distance comfort – and thus displays the characteristic attributes of a true AMG. The Electronic Stability Program ESP<sup>®</sup> has been specially adapted in line with the high level of driving

dynamics, as it allows the driver to select the level of assistance provided by the dynamic handling control system by choosing one of three different control settings: ON, OFF and SPORT HANDLING MODE. The activated setting is shown on the AMG instrument cluster's central display. The AMG high-performance braking system featuring large, internally ventilated and perforated brake discs ensures outstanding levels of deceleration. Not to mention perfect brake control, extremely short stopping distances and excellent fade resistance.

Also available is the optional AMG performance suspension. With its sportier spring and damper tuning this suspension responds even faster and more directly to meet the very highest dynamic handling requirements.

<sup>1</sup> Integral component of Mercedes-Benz Intelligent Drive. More on page 28.

### AMG SPEEDSHIFT MCT 7-speed sports transmission.

Equipped with AMG aluminium steering-wheel shift paddles, four modes and a Race Start function, the 7-speed automatic transmission delivers enhanced driving dynamics and is highly efficient. The “S” (Sport), “S+” (Sport Plus), “C” (Comfort) and “M” (Manual) modes each have different gear-change characteristics and speeds: gear changes in “S” and “S+” modes are around 20 or 40 percent quicker than in “C” mode respectively – while in “M” mode gear changes take just 100 milliseconds, making them some 50 percent faster. A push of a button activates the desired driving mode: distinctly sporty or more comfort-oriented. There is also an automatic double-declutching function when downshifting, which provides an emotive sound experience as well as reducing power-off effects. This function has a positive effect when braking on the approach to bends in particular.



The AMG SPEEDSHIFT MCT 7-speed sports transmission offers customised modes for maximum driving pleasure.



Motor-racing technology gives the AMG 6.3-litre V8 engine maximum agility.





## AMG Performance Studio.

An even sportier look for the C 63 AMG is available in the AMG Performance Studio. The AMG Performance package, for example, includes an increased output of 22 kW (30 hp), the AMG performance steering wheel in nappa leather/ DINAMICA microfibre, the AMG high-performance compound braking system at the front axle, the AMG carbon-fibre spoiler lip, brake callipers painted red at the front and rear, plus a variable intake manifold painted in titanium grey. Vehicle-specific data and route information can be visualised and evaluated using AMG Performance Media – a unique highlight for racing enthusiasts. The AMG Driver's Package increases the maximum speed of the vehicle to 280 km/h and includes a driver training session at the AMG Driving Academy. What's more, the AMG Performance Studio meets individual customer requirements – right down to one-off features.

---

### AMG Performance Studio

AMG carbon-fibre trim

AMG door sill panels, illuminated with white LEDs

AMG Exterior Carbon-Fibre package (AMG carbon-fibre spoiler lip and exterior mirror housings)

AMG floor mats

AMG multi-spoke light-alloy wheels, painted titanium grey or matt black, with 235/35 R 19 tyres at the front and 255/30 R 19 tyres at the rear

AMG Performance Media

AMG performance suspension

AMG rear-axle differential lock

---

## Standard equipment | Selection.



Daytime running lamps and front fog lamps.



3-spoke multifunction steering wheel with 4 buttons, in nappa leather, perforated in the grip area.



THERMATIC automatic climate control.



Coupé seats.



LED tail lights.



Audio 20 CD with Bluetooth® interface.



ECO start/stop function.



USB connection.

## Optional extras | Selection.



Heat-insulating tinted rear window and rear side windows.



Panoramic sliding sunroof.



3-spoke multifunction steering wheel with 12 buttons, in nappa leather, perforated in the grip area.



KEYLESS-GO drive authorisation system.



Intelligent Light System<sup>1</sup>.



Mirror package.



COMAND Online multimedia system with LINGUATRONIC.



Media Interface.



## AMG Sports package.

The optionally available AMG Sports package lends the C-Class Coupé an even more dynamic and athletic appearance as well as enhancing its sporty agility. On the outside, it emphasises the coupé's visible forwards thrust with AMG 7-spoke light-alloy wheels and AMG bodystyling, including front and rear aprons as well as side sill panels. The AMG Sports package also includes sports suspension and speed-sensitive sports steering to emphasise the car's effortlessly superior agility.



---

### Exterior

---

AMG 7-spoke light-alloy wheels with mixed-size tyres: 225/40 R 18 at the front and 255/35 R 18 at the rear

---

AMG bodystyling, comprising front apron, side sill panels and rear apron

---

Lowered sports suspension

---

Perforated front brake discs, brake callipers with "Mercedes-Benz" lettering

---

Speed-sensitive sports steering

---

Tailpipe trim in polished stainless steel

---



The unique features of the optionally available AMG Sports package lend the interior of the C-Class Coupé extra dynamic touches: the 3-spoke multifunction sports steering wheel with a flattened bottom section allows the driver to change gear using steering-wheel gearshift paddles (only in conjunction with automatic transmission), while the speed-sensitive sports steering enhances the car's sporty handling. The headlining is finished in black fabric. A generously sized instrument cluster with an 11.4 cm colour display and ATTENTION ASSIST<sup>1</sup> catches the eye without distracting the driver's attention from the road. The sporty interior is rounded off perfectly by an aluminium trim, brushed stainless-steel sports pedals and AMG floor mats.



---

#### Interior

3-spoke multifunction sports steering wheel with flattened bottom section and 12 buttons, in nappa leather, perforated in the grip area

ATTENTION ASSIST system

Brushed stainless-steel sports pedals with rubber studs

Dark longitudinal-grain aluminium trim

Floor mats in black with "AMG" lettering

Headlining in black

Instrument cluster with high-resolution 11.4 cm colour display

Steering-wheel gearshift paddles (only with automatic transmission)

---

<sup>1</sup> Integral component of Mercedes-Benz Intelligent Drive. More on page 28.



## AMG Plus Sports package.

The dynamic lines of the C-Class become even more intensive with the AMG Plus Sports package. This brings out the sporty essence of the model by applying the inimitable AMG treatment in numerous areas. In specific terms this means: AMG bodystyling with front and rear aprons as well as side sill panels, an AMG spoiler lip in the vehicle colour on the boot lid and exclusive AMG 7-twin-spoke light-alloy wheels. The systematic application of the AMG treatment also extends to the details: perforated front brake discs, brake callipers with “Mercedes-Benz” lettering and polished stainless-steel tailpipe embellishers. But it is not just the vehicle’s looks that are enhanced. The speed-sensitive sports steering and sports suspension ensure that the driving dynamics deliver all that the appearance promises.

---

### Exterior

---

AMG 7-twin-spoke light-alloy wheels, painted in high-gloss black with a high-sheen finish

---

AMG bodystyling, comprising front apron, side sill panel and rear apron

---

AMG spoiler lip on the boot lid

---

Callipers with “Mercedes-Benz” lettering, perforated front brake discs

---

Lowered sports suspension

---

Speed-sensitive sports steering

---

Tailpipe trim in polished stainless steel

---



The sporty theme continues inside the vehicle: red topstitching on the AMG sports seats and red designo seat belts are complemented by silver-effect shift paddles on the 3-spoke multifunction sports steering wheel. Aluminium trim as well as black floor mats with “AMG” lettering and a red surround complete the interior, along with the brushed stainless-steel sports pedals. Together, these features add a distinctly sporty dimension to every trip – even the daily commute.

---

#### Interior

3-spoke multifunction sports steering wheel, with a flattened bottom section, with twelve buttons, in nappa leather and with contrasting topstitching in red, perforated in grip area

AMG floor mats in black with red surround

AMG sports seats with integral head restraints and single rear seats

Armrest, centre console, door centre panels and selector lever gaiter with contrasting topstitching in red

ATTENTION ASSIST<sup>1</sup>

Dark longitudinal-grain aluminium trim

designo seat belts in red (can be deselected in favour of black seat belts)

Headlining in black

Instrument cluster with high-resolution 11.4 cm colour display

Sports pedals in brushed stainless steel with rubber studs (also for foot-operated parking brake)

Steering-wheel gearshift paddles, silver-coloured (only in conjunction with automatic transmission)

Upholstery in ARTICO man-made leather/DINAMICA microfibre in black or in black leather (option)



<sup>1</sup> Integral component of Mercedes-Benz Intelligent Drive. More on page 28.

## designo.

The designo range allows you to design the C-Class Coupé to an even higher standard and to your own taste. → [www.mercedes-benz.com/designo](http://www.mercedes-benz.com/designo)

The wide range of exclusive designo appointments allows you to personalise an already exceptional vehicle. Single-tone appointments including seats and armrests in designo leather and leather-trimmed door centre panels featuring a hallmark designo look create a high-quality, exclusive atmosphere, whether you choose the designo leather in sand, black, porcelain or classic red. And should you wish to emphasise your coupé's individuality even more, designo offers plenty of further possibilities. An optional two-tone designo steering wheel offers the perfect complement to this exclusive designo interior.



The two-tone appointments in designo leather highlight the coupé's sporty, dynamic side. There is a choice of combinations available for the designo leather: sand/black, porcelain/black or classic red/black. As in all Mercedes-Benz models, the metal badge in the backrest is proof of meticulous material selection, exceptional quality, careful craftsmanship and individuality at the highest level. The interior is completed by the extended appointments in designo black leather comprising a leather finish for the upper section of the dashboard.



## Style package.

The Style package further emphasises the sporty and individual interior style of the C-Class Coupé.

The Style package comprises a number of high-quality, harmoniously combined details. The upholstery in black ARTICO man-made leather with contrasting porcelain-coloured topstitching catches the eye straight away.



Handcrafted perfection: the Style package individualises the interior of the C-Class Coupé.

The 3-spoke multifunction sports steering wheel with twelve buttons is trimmed in leather with a two-tone look, the lower section being finished in porcelain-coloured leather. The surface is perforated so that it is even easier to grip. This style is consistently matched by the trim, which is also in a porcelain colour but with a piano-lacquer look.



All the details combine to paint an impressive overall picture: the porcelain-coloured trim shines with a piano-lacquer look.

The armrests, the door panelling, the shift/selector lever gaiter and the centre console are accentuated by contrasting topstitching in a porcelain colour, while the floor mats have porcelain-coloured edging.



Gearshift gaiter with contrasting topstitching in a porcelain colour.

## Upholstery and trim.



The seat upholstery in ARTICO man-made leather/fabric in black, included as standard, adds the perfect finishing touches to the coupé's seats. The 3-spoke multifunction steering wheel is trimmed in nappa leather, while the headlining is finished in alpaca grey fabric. The A-, B- and C-pillars are likewise in alpaca grey. Black is the colour used for the dashboard, the load compartment cover and the door panelling. A black piano-lacquer-look trim tastefully rounds off the interior design. The trim for the dashboard, centre console and doors is also optionally available in aluminium with a dark longitudinal grain or in matt brown ash wood.



401



H80



739



H06

### black

401 ARTICO man-made leather/fabric

### Trim

H80 high-gloss black piano-lacquer look

739 dark longitudinal-grain aluminium<sup>1</sup>

H06 matt brown ash wood<sup>1</sup>

<sup>1</sup> Optional extra.



The seat upholstery in ARTICO man-made leather/fabric in alpaca grey, included as standard, adds the perfect finishing touches to the coupé's seats. The 3-spoke multifunction steering wheel is trimmed in nappa leather, while the headlining is finished in alpaca grey fabric. The A-, B- and C-pillars and the door panelling are likewise in alpaca grey. The "split" dashboard is finished in black and alpaca grey, while the load compartment cover is black. A black piano-lacquer-look trim tastefully rounds off the interior design. The trim for the dashboard, centre console and doors is also optionally available in dark longitudinal-grain aluminium or in matt brown ash wood.

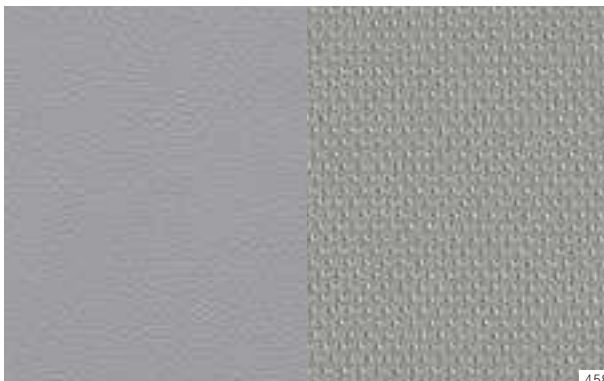

458

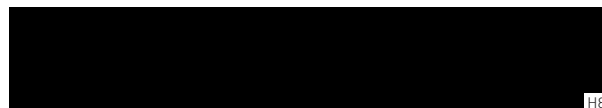

H80



739



H06

---

**alpaca grey**

---

458 ARTICO man-made leather/fabric

---

**Trim**

---

H80 high-gloss black piano-lacquer look

739 dark longitudinal-grain aluminium<sup>1</sup>H06 matt brown ash wood<sup>1</sup><sup>1</sup> Optional extra.



At the heart of the optional black colour scheme are the seats in a choice of black ARTICO man-made leather or black leather with alpaca grey topstitching. The 3-spoke multifunction steering wheel is trimmed in black nappa leather. The door panelling is also kept in black, while the headlining is finished in black fabric. The A-, B- and C-pillars, the dashboard and the load compartment cover are likewise in black. A dark aluminium trim tastefully rounds off the interior design. The trim for the dashboard, centre console and doors is also optionally available in a high-gloss black piano-lacquer look or in matt brown ash wood.



---

**black**

141 ARTICO man-made leather<sup>1</sup>

211 leather<sup>1</sup>

---

**Trim**

739 dark longitudinal-grain aluminium

H80 high-gloss black piano-lacquer look<sup>1</sup>

H06 matt brown ash wood<sup>1</sup>

---

<sup>1</sup> Optional extra.



At the heart of the optional alpaca grey colour scheme are the seats in a choice of ARTICO man-made leather or leather in alpaca grey with dark alpaca grey topstitching. The 3-spoke multifunction steering wheel is trimmed in black nappa leather. The door panelling is kept in alpaca grey, while the load compartment cover is in black. The headlining is finished in black fabric, while the A-, B- and C-pillars are likewise in black. The “split” dashboard is finished in black and alpaca grey. A dark aluminium trim tastefully rounds off the interior design. The trim for the dashboard, centre console and doors is also optionally available in a high-gloss black piano-lacquer look or matt brown ash wood instead of aluminium.



---

#### alpaca grey

118 ARTICO man-made leather<sup>1</sup>

268 leather<sup>1</sup>

---

#### Trim

739 dark longitudinal-grain aluminium

H80 high-gloss black piano-lacquer look<sup>1</sup>

H06 matt brown ash wood<sup>1</sup>

---

<sup>1</sup> Optional extra.



At the heart of the optional saharabeige colour scheme are the seats in saharabeige leather with topstitching in the same colour. The 3-spoke multifunction steering wheel is trimmed in black nappa leather. The door panelling is kept in saharabeige, while the roof lining is finished in black fabric. The A-, B- and C-pillars, the dashboard and the load compartment cover are likewise in black. A dark aluminium trim tastefully rounds off the exclusive interior design. The trim for the dashboard, centre console and doors is also optionally available in a high-gloss black piano-lacquer look or in matt brown ash wood.



215



739

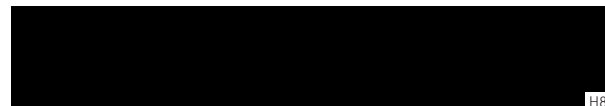

H80



H06

---

**saharabeige**
215 leather<sup>1</sup>

---

**Trim**

739 dark longitudinal-grain aluminium

H80 high-gloss black piano-lacquer look<sup>1</sup>H06 matt brown ash wood<sup>1</sup>

---

<sup>1</sup> Optional extra.



At the heart of the optional bengal red colour scheme are the seats in bengal red leather with black topstitching. The 3-spoke multifunction steering wheel is trimmed in black nappa leather. The door panelling is kept in bengal red, while the headlining is finished in black fabric. The A-, B- and C-pillars, the dashboard and the load compartment cover are likewise in black. A dark aluminium trim tastefully rounds off the interior design. The trim for the dashboard, centre console and doors is also optionally available in a high-gloss black piano-lacquer look or in matt brown ash wood.



267



739



H80



H06

---

**bengal red**
267 leather<sup>1</sup>

---

**Trim**

739 dark longitudinal-grain aluminium

H80 high-gloss black piano-lacquer look<sup>1</sup>H06 matt brown ash wood<sup>1</sup>

---

<sup>1</sup> Optional extra.

## Wheels.



5-spoke light-alloy wheels with 225/40 R 18 front tyres and 255/35 R 18 rear tyres, painted in "sterling silver" (optional, Code R36).



10-spoke light-alloy wheels with 245/45 R 17 tyres (standard for C 200, C 250 CDI, C 250 and C 350, Code 25R).



7-spoke light-alloy wheels with 225/45 R 17 front tyres and 245/40 R 17 rear tyres, painted high-gloss black with a high-shine finish (optional, Code 74R).



5-twin-spoke light-alloy wheels with 225/45 R 17 front tyres and 245/40 R 17 rear tyres (optional, Code R95).



Multi-spoke light-alloy wheels with 225/45 R 17 front tyres and 245/40 R 17 rear tyres (optional, Code 56R).



7-spoke AMG light-alloy wheels with 225/40 R 18 front tyres and 255/35 R 18 rear tyres (standard wheels for AMG Sports package, Code 782).



7-spoke AMG light-alloy wheels with 225/40 R 18 front tyres and 255/35 R 18 rear tyres, painted in high-gloss black and with a high-sheen finish (optional for all Sports packages and Sport models, Code 661).



5-twin-spoke AMG light-alloy wheels, painted titanium grey with a high-sheen finish, with 235/40 R 18 front tyres and 255/35 R 18 rear tyres (standard for C 63 AMG, Code 795).



Multi-spoke AMG light-alloy wheels, painted titanium grey with a high-sheen finish, with 235/35 R 19 front tyres and 255/30 R 19 rear tyres (optional for C 63 AMG, Code 788).



7-twin-spoke AMG light-alloy wheels with 225/40 R 18 front tyres and 255/35 R 18 rear tyres, painted in titanium grey with a high-sheen finish (standard for AMG Plus Sports package and Sport models, Code 760).



5-twin-spoke AMG light-alloy wheels with 225/40 R 18 front tyres and 255/35 R 18 rear tyres (optional, Code 786).



5-spoke AMG light-alloy wheels, painted titanium grey with a high-sheen finish, with 235/40 R 18 front tyres and 255/35 R 18 rear tyres (optional for C 63 AMG, Code 790).



Multi-spoke AMG light-alloy wheels, painted matt black, rim flange with a high-sheen finish, with 235/35 R 19 front tyres and 255/30 R 19 rear tyres (optional for C 63 AMG, Code 797).



Basic carrier bars and Mercedes-Benz roof box.

## Genuine accessories.

The C-Class Coupé is a special car. The extensive range of Mercedes-Benz genuine accessories enables you to add further high-quality individuality.

→ [www.mercedes-benz-accessories.com](http://www.mercedes-benz-accessories.com)

With genuine accessories from Mercedes-Benz, the C-Class Coupé can be made to reflect its owner's personal lifestyle. Those who like to travel with lots of luggage or sports equipment can add further stowage space by opting for the reliable and flexible carrier system and a 450 roof box which is easy to load and unload. The roof box is available in a choice of three sizes: either approx. 450 litres or 400 litres or as a sports box with a capacity of around 330 litres. All boxes can be opened on both sides. Optional extras include a luggage set and a ski rack attachment.

A car as individual as the C-Class Coupé greets you every time you get in and out: with white-illuminated "Mercedes-Benz" lettering on the polished stainless-steel door sill panels.

Thanks to their distinctive styling, the high-end-design light-alloy wheels further emphasise the individual aura of the C-Class Coupé. These light-alloy wheels are available in a choice of sizes and designs, for example 5-twin-spoke wheels with mixed-size tyres: 225/40 R 18 at the front and, optionally, 255/35 R 18 at the rear.

The range of genuine accessories offers a wide selection of high-quality products to choose from. Please see our accessories brochure for further details, or contact your Mercedes-Benz dealer who will be pleased to advise you.



Roof rack with "Luxury" ski and snowboard rack.



Illuminated door sill panels with "Mercedes-Benz" lettering.



5-twin-spoke light-alloy wheels<sup>1</sup> (genuine accessories).

<sup>1</sup> Light-alloy wheels from the genuine accessories range are supplied without tyres.

## Services.

**Mercedes-Benz Financial Services.** Our sophisticated leasing and financing products are tailored to your individual financial needs, giving you the opportunity to drive your dream car while staying financially flexible. Once you have chosen a model, you can enjoy the peace of mind of knowing that both the vehicle itself and our insurance products will keep you particularly well protected. What's more, our range of service products is designed to ensure that your car stays in top shape while offering transparent, manageable conditions. For further details, speak to your Mercedes-Benz dealer, who will be glad to go through the latest financial services and terms and conditions with you.

**Mercedes-Benz mobility.** Your new car comes complete with the promise of feeling safe on the road. But if you should ever need assistance, Mercedes-Benz Service24h is there to help. Just call the freephone service hotline on 00800 1 777 7777<sup>1</sup>. The integrated telematics service, Mercedes-Benz Contact<sup>2</sup>, is even more convenient: a touch of a button is all it takes to contact the Mercedes-Benz customer centre. If you wish, relevant vehicle and position-related data are transmitted at the same time, thereby allowing the centre to react quickly and provide rapid on-site assistance. Also standard with your new car at no extra charge is the Mercedes-Benz Mobilo<sup>3</sup> mobility package. Whether you have lost your key, had a breakdown which cannot be repaired immediately or suffered damage to the vehicle due to an accident or vandalism, Mobilo helps you reach your destination – anywhere in Europe. Whatever is holding you up, you will soon be able to resume your journey.

**Mercedes-Benz Museum.** Discover what has been moving the world for over 125 years, and embark on a fascinating journey through automotive history in the Mercedes-Benz Museum. More than 1500 exhibits covering an area of 16,500 square metres chart the unique heritage and innovative flair of the inventor of the motor car. You will find one automotive legend after another awaiting you: unique pieces such as the oldest Mercedes still in existence from 1902, supercharged cars or the awe-inspiring Gullwings. The museum is a spectacular sight in its own right too, thanks to an architecture that breaks away from traditional concepts and creates an unprecedented sense of space. Welcome to the Mercedes-Benz Museum – a world of innovation. [www.mercedes-benz-classic.com/museum](http://www.mercedes-benz-classic.com/museum)



<sup>1</sup> Alternative: +49 69 95 30 72 77. <sup>2</sup> Requires a factory-fitted radio, connected to an operational mobile phone. The only charge incurred is the cost of the mobile phone call to the landline network. <sup>3</sup> Once the mobility guarantee has expired (four years), Mobilo can be extended to provide cover in the event of breakdown and insurance claims one year at a time for a maximum of 30 years, provided that regular maintenance is carried out by your Mercedes-Benz service partner.

**Test drive.** The unique feeling of driving a Mercedes cannot be put into words – you have to experience it for yourself. Take a test drive and find out first hand how it feels to drive your dream car. Please contact your nearest Mercedes-Benz dealer for details.

#### **Interactive Owner's Manual and Mercedes-Benz Guides.**

The website also offers an interactive tour, enabling you to acquaint yourself with your dream car. You can view key functions in detail, gain an insight into the car's inner workings or look at the benefits of each model. For further details, go to [www.mercedes-benz.de/owners-manual](http://www.mercedes-benz.de/owners-manual). The "Mercedes-Benz Guides" app lets you explore the highlights of the individual models both online and offline. The app is available free of charge from the Apple® iTunes® Store (iOS) as well as the Google Play store (Android).

**Mobile internet.** The whole world of Mercedes-Benz can be explored at any time with your web-capable mobile device – including specially adapted content for both smartphones and tablets. As well as an overview of all the passenger car models, there are insights into the entire brand world along with a wealth of entertainment offers and direct links to our range of services at [www.mercedes-benz.com](http://www.mercedes-benz.com)

**Mercedes-Benz service contracts.** You need never worry about unexpected workshop costs<sup>4</sup> again: depending on the specific contract, a Mercedes-Benz service contract can cover unforeseen repairs, maintenance or wear parts. As a result, your vehicle stays in great condition – thanks to the Mercedes-Benz quality you can expect from our highly qualified workshop specialists and Mercedes-Benz genuine parts. Your Mercedes-Benz dealer will be pleased to tell you more about the available service contracts and terms and conditions.



**Accident repairs.** Should the worst happen and you find yourself in need of repairs, with the Mercedes-Benz accident repair service you will receive the right assistance for your vehicle and ensure that its high-quality safety features are properly maintained. Whether you need paint, body or glass repair work carried out, the highly trained specialists at your Mercedes-Benz service partner will repair your Mercedes-Benz and get you quickly back on the road again. Further information is available from your authorised Mercedes-Benz dealer.



<sup>4</sup> In accordance with the terms and conditions of the Mercedes-Benz service contracts.

## Dimensions.

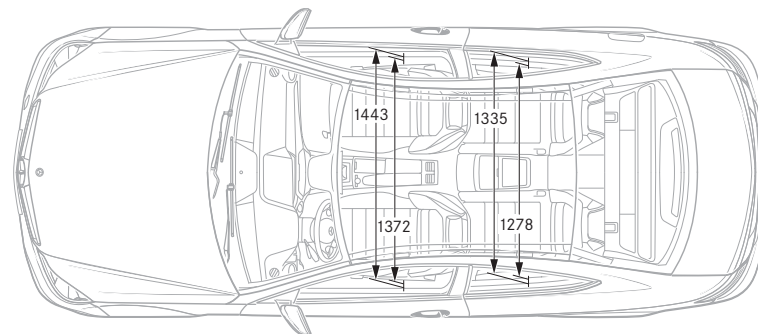
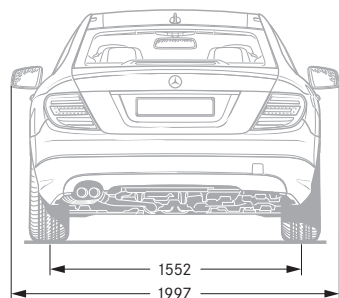
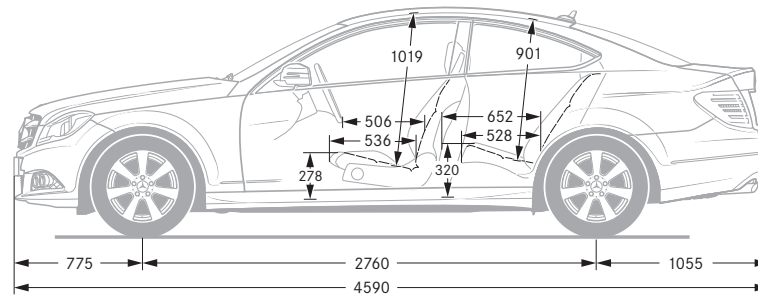
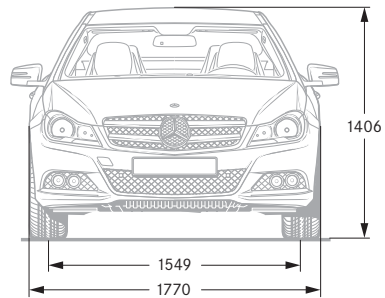

## Paintwork.

The paint system developed by Mercedes-Benz includes one of the best clearcoats on the automotive market and is a key factor behind the car's excellent value retention. The secret lies in the exceptionally dense molecular structure, which makes both the metallic and the non-metallic clearcoats more resistant and produces a longer-lasting and visibly more intensive shine.

### Non-metallic paints (standard)

- 040 black
- 149 polar white
- 590 fire opal

### Metallic paints (option)

- 183 magnetite black
- 197 obsidian black
- 755 tenorite grey
- 775 iridium silver
- 792 palladium silver
- 890 cavansite blue
- 988 diamond silver

### Special paints (option)

- 051 designo magno platinum (option for C-Class Coupé Sport)
- 799 diamond white metallic BRIGHT

## Technical data.

	Diesel engines			
	C 220 CDI	C 220 CDI BlueEFFICIENCY Edition	C 250 CDI	C 250 CDI Sport
No. of cylinders/arrangement	4/in-line	4/in-line	4/in-line	4/in-line
Total displacement in cc	2143	2143	2143	2143
Rated output <sup>1</sup> in kW (hp) at rpm	125 (170)/3000-4200	125 (170)/3000-4200	150 (204)/4200	150 (204)/4200
Rated torque <sup>1</sup> in Nm at rpm	400/1400-2800	400/1400-2800	500/1600-1800	500/1600-1800
Acceleration from 0 to 100 km/h in s	8.4 [8.1]	8.4	7.0 [7.1]	- [7.1]
Top speed, approx. in km/h	232 [231]	232	240 [240]	- [240]
Tyre size - front axle, rear axle	205/55 R 16	205/55 R 16	225/45 R 17	225/40 R 18, 255/35 R 18
Fuel	Diesel	Diesel	Diesel	Diesel
Fuel consumption <sup>3</sup> in l/100 km				
Urban	6.3-5.6 [6.5-6.1]	5.2	6.8-6.2 [6.5-6.1]	- [6.5]
Extra-urban	4.3-3.7 [4.6-4.2]	3.5	4.6-4.1 [4.6-4.2]	- [4.6]
Combined	5.1-4.4 [5.3-4.9]	4.1	5.4-4.9 [5.3-4.9]	- [5.3]
CO <sub>2</sub> emissions <sup>3</sup> in g/km combined	133-117 [139-128]	109	143-128 [139-128]	- [139]
Efficiency class	A [A]	A+	A [A]	- [B]
Emission class	Euro 5	Euro 5	Euro 5	Euro 5
Tank capacity in l/incl. approx. reserve	59/8	59/8	59/8	59/8
Boot capacity in l	450	450	450	450
Turning circle diameter in m	10.84	10.84	10.84	10.84
Kerb weight <sup>4</sup> in kg	1615 [1630]	1615	1655 [1660]	- [1660]
Perm. GVW in kg	2085 [2100]	2085	2125 [2130]	- [2130]

<sup>1</sup> Figures in accordance with Directive 80/1269/EEC in the currently applicable version. <sup>2</sup> Electronically governed. <sup>3</sup> The figures shown were obtained in accordance with the prescribed measuring process (Directive [EC] 715/2007 in the currently applicable version).  
<sup>4</sup> The figures are not based on an individual model and do not constitute part of the product offer; they are provided solely for purposes of comparison between different vehicle models.

## Petrol engines

C 180	C 200	C 250	C 250 Sport	C 350	C 63 AMG	
					Without Performance package	With Performance package
4/in-line	4/in-line	4/in-line	4/in-line	6/V	8/V	8/V
1595	1796	1796	1796	3498	6208	6208
115 (156)/5300	135 (184)/5250	150 (204)/5500	150 (204)/5500	225 (306)/6500	336 (457)/6800	358 (487)/6800
250/1250-4000	270/1800-4600	310/2000-4300	310/2000-4300	370/3500-5250	600/5000	600/5000
8.5 [8.5]	8.2 [7.8]	- [7.2]	- [7.2]	- [6.0]	- [4.4]	- [4.3]
225 [223]	237 [235]	- [240]	- [240]	- [250] <sup>2</sup>	- [250] <sup>2</sup>	- [250] <sup>2</sup>
195/60 R 16	225/45 R 17	225/45 R 17	225/40 R 18, 255/35 R 18	225/45 R 17	235/40 R 18, 255/35 R 18	235/40 R 18, 255/35 R 18
Premium petrol	Premium petrol	Premium petrol	Premium petrol	Premium petrol	Super Plus petrol	Super Plus petrol
8.1-7.7 [8.0-7.7]	9.8-9.3 [9.1-8.8]	- [9.1-8.8]	- [9.1]	- [9.6-9.4]	- [18.2]	- [18.2]
5.4-4.7 [5.3-4.8]	5.8-5.2 [5.7-5.2]	- [5.7-5.2]	- [5.7]	- [5.6-5.3]	- [8.4]	- [8.4]
6.4-5.8 [6.3-5.8]	7.2-6.6 [7.0-6.5]	- [7.0-6.5]	- [7.0]	- [7.0-6.8]	- [12.0]	- [12.0]
149-136 [147-136]	168-154 [163-152]	- [163-152]	- [163]	- [164-159]	- [280]	- [280]
B [B]	C [C]	- [C]	- [D]	- [C]	- [G]	- [G]
Euro 6	Euro 5	Euro 5	Euro 5	Euro 5	Euro 5	Euro 5
59/8	59/8	59/8	59/8	66/8	66/14	66/14
450	450	450	450	450	450	450
10.84	10.84	10.84	10.84	10.84	11.10	11.10
1490 [1505]	1540 [1545]	- [1550]	- [1550]	- [1615]	- [1730]	- [1730]
1960 [1975]	2010 [2015]	- [2020]	- [2020]	- [2085]	- [2160]	- [2160]

<sup>4</sup> Figures in accordance with Directive 92/21/EC, version 95/48/EC (kerb weight with fuel tank 90% full, driver, 68 kg, and luggage, 7 kg) for standard-specification vehicles. Optional extras and accessories will generally increase this figure and reduce the payload capacity accordingly. Figures in square brackets refer to engines with an automatic transmission. Further technical data can be found at [www.mercedes-benz.com](http://www.mercedes-benz.com)

Non-metallic paints

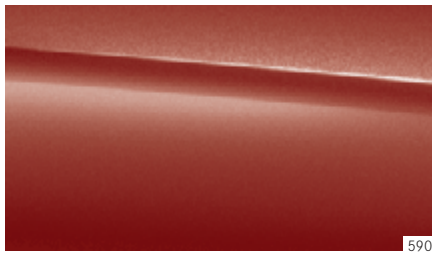

Metallic paints

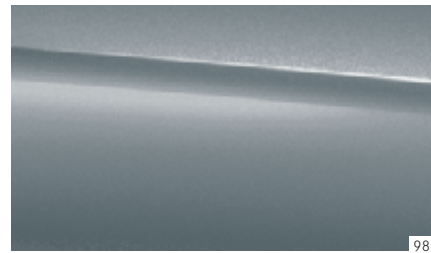
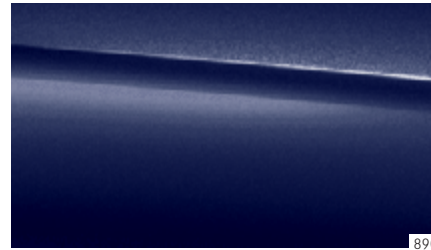
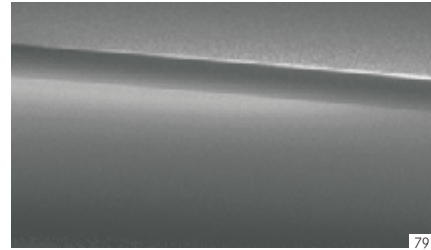
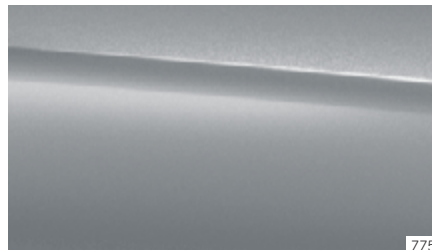
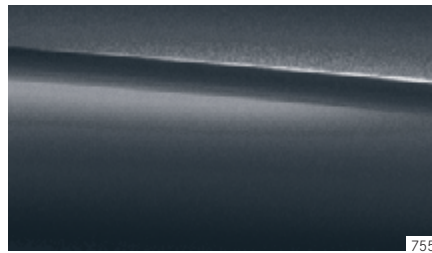
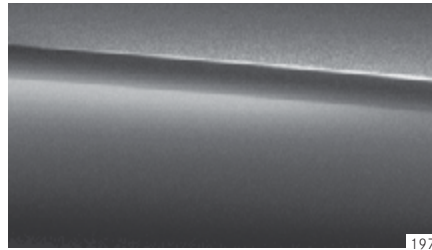
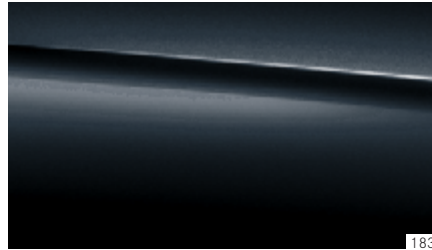

Special paints

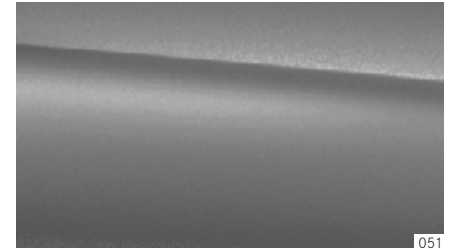

**Take-back of end-of-life vehicles.** You can return your C-Class to us for environment-friendly disposal in accordance with the European Union (EU) End-Of-Life Vehicle Directive. But that day lies a long way off.

A network of vehicle take-back depots and dismantlers has been established to make it as easy as possible for you to return your vehicle. You can leave it at any of these points free of charge and, by doing so, make an important contribution to completing the recycling process and conserving resources.

For further information about the recycling and disposal of end-of-life vehicles, and the take-back conditions, please visit the national Mercedes-Benz website.

**Please note:** changes may have been made to the product since this brochure went to press (18.02.2013). The manufacturer reserves the right to make changes to the design, form, colour and specification during the delivery period, provided these changes, while taking into account the interests of the vendor, can be deemed reasonable with respect to the purchaser. Where the vendor or the manufacturer uses symbols or numbers to describe an order or the subject of an order, no rights may be derived solely from these. The illustrations may show accessories and items of optional equipment which are not part of standard specification. Colours may differ slightly from those shown in the brochure, owing to the limitations of the printing process. This brochure is distributed internationally. It provides a general indication of the range of models, features, optional extras, colours and/or services available in various countries. Some of the models, features, optional extras, colours and/or services shown may not be available in your country or may only be available in a different specification. Additionally some models, features, optional extras, colours and/or services may only be available in combination with others. For current and more specific information in relation to the range of models, features, optional extras, colours and/or services available in your country, and their pricing, you should contact your nearest authorised Mercedes-Benz Passenger Car Dealer.

[www.mercedes-benz.com](http://www.mercedes-benz.com)